



Seitenkanal-
Vakuumpumpen

Side channel
vacuum pumps

Turbine latérale
vide

Pompe per vuoto
a canali laterali

G-SMV



G-SMV 160

G-SMV 300

G-SMV 500

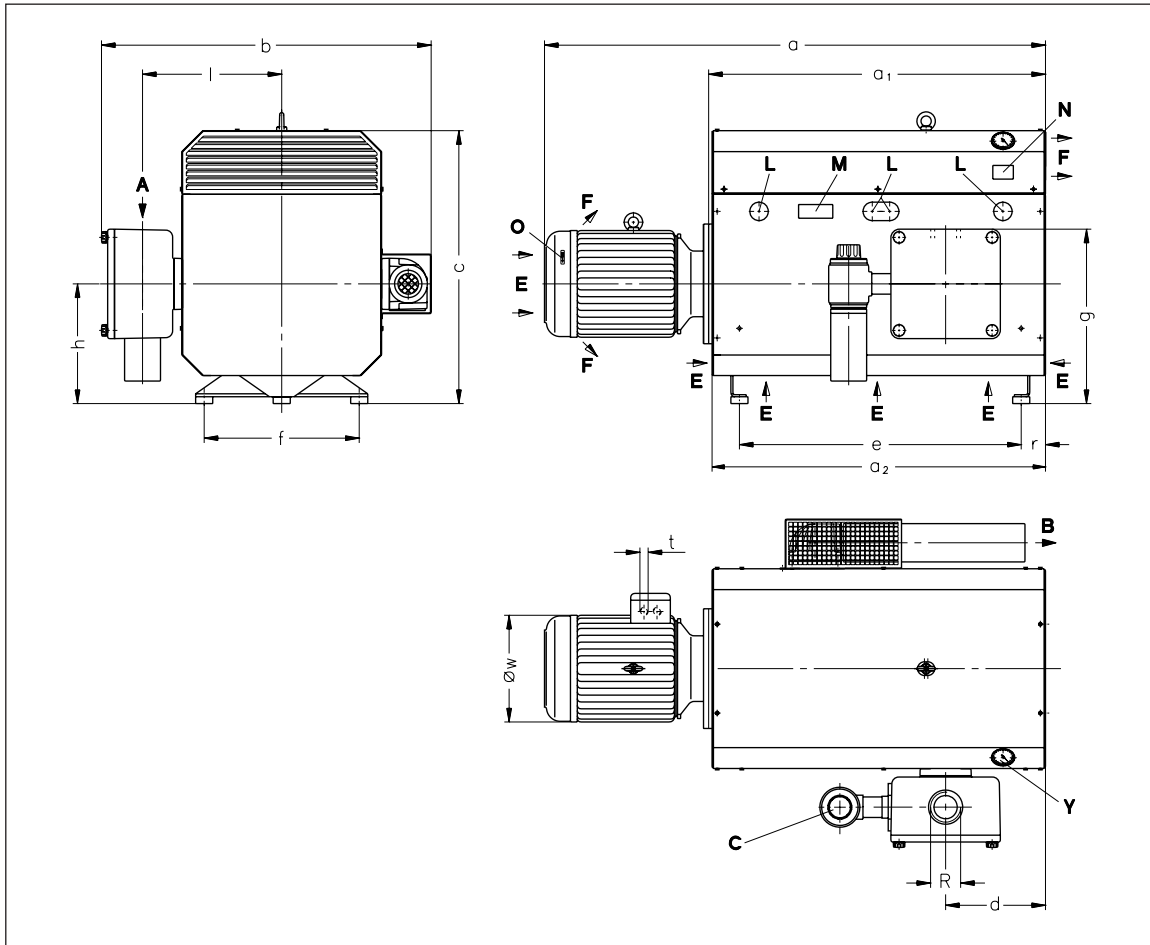

A	Vakuum-Anschluss	Vacuum connection	Raccord du vide	Attacco vuoto
B	Abluft-Austritt	Exhaust	Refolement	Scarico aria
C	Vakuum-Regulierventil	Vacuum regulating valve	Valve réglage vide	Valvola regolazione vuoto
E	Kühlluft-Eintritt	Cooling air entry	Entrée air refroidissement	Entrata aria di raffreddamen.
F	Kühlluft-Austritt	Cooling air exit	Sortie air refroidissement	Uscita aria di raffreddamento
L	Schmierstellen	Greasing points	Points de graissage	Punti di lubrificazione
M	Schmierschild	Greasing label	Etiquette graissage	Targhetta della lubrificazione
N	Datenschild	Data plate	Etiquette caractéristique	Targhetta dati
O	Drehrichtungsschild	Direction of rotation	Flèche sens rotation	Targhetta senso rotazione
Y	Vakuummeter	Vacuum gauge	Vacuomètre	Manovuotometro

G-SMV		160	300	500
[mm]	a 50/60 Hz	1196	1200 / 1312	1476
	a ₁ 50/60 Hz	795	795 / 825	977
	a ₂	797	797	975
	b	811	811	965
	c	652	652	799
	d	239	239	292
	e	632	632	824
	f	362	362	498
	g	395	395	510
	h	285	285	350
	l	329	329	407
	r	103	103	71
	t 50/60 Hz	M 32 x 1,5	M 32 x 1,5 / M 40 x 1,5	M 40 x 1,5
	øw 50/60 Hz	246	246 / 312	312
	R	G 2	G 2	G 3

D 561

2.11.99

**Gardner Denver
Schopfheim GmbH**

Postfach 1260
79642 SCHOPFHEIM
GERMANY

Fon +49 7622 / 392-0

Fax +49 7622 / 392-300

e-mail: info.sch@
de.gardnerdenver.com

www.gd-elmorietschle.com

G-SMV		160	300	500
m ³ /h	50 Hz	180	300	470
	60 Hz	215	350	560
mbar (abs.) •	50 Hz	150 (200)	100 (200)	
	60 Hz	100 (200)	60 (200)	
3~	50 Hz	400/690V ± 10 %		
	60 Hz	380/660V		
kW	50 Hz	5,5	7,5	15,0
	60 Hz	9,0	11	18,0
A	50 Hz	11,5/6,6	18,5/10,7	30,4/17,5
	60 Hz	19,4/11,2	23,0/13,3	38,7/22,4
min ⁻¹	50 Hz	2920		
	60 Hz	3450		
dB(A)	50 Hz	78	78	82
	60 Hz	84	84	86
kg	50 Hz	202	210	382
	60 Hz	210	214	382
ZRK		50 (03)	50 (03)	80 (03)
ZMS	50 Hz	160/100	200/160	-/200
	60 Hz	200/160	250/160	-/250

m ³ /h	Saugvermögen	Capacity	Débit	Portata
mbar (abs.) •	Endvakuum max. (im Dauerbetrieb)	Ultimate vacuum max. (on continuous operation)	Vide limite maxi. (en fonctionnement continu)	Vuoto finale massimo (in funzionamento continuo)
mbar (abs.)	Ansaugdruck	Suction pressure	Pression d'aspiration	Pressione di aspirazione
3~	Motorausführung	Motor version	Exécution moteur	Esecuzione motore
kW	Motorleistung	Motor rating	Puissance moteur	Potenza motore
A	Stromaufnahme	Current drawn	Intensité absorbée	Corrente nominale
min ⁻¹	Drehzahl	Speed	Vitesse rotation	Numero giri
dB(A) → DIN 45635	Mittlerer Schalldruckpegel	Average noise level	Niveau sonore moyen	Rumorosità media
kg	Max. Gewicht	Maximum weight	Poids maxi.	Peso massimo
ZRK	Zubehör	Optional extras	Accessoires	Accessori
ZMS	Rückschlagventil	Non-return valve	Clapet anti-retour	Valvola di non ritorno
	Motorschutzschalter	Motor starter	Disjoncteur moteur	Interruttore magnetotermico

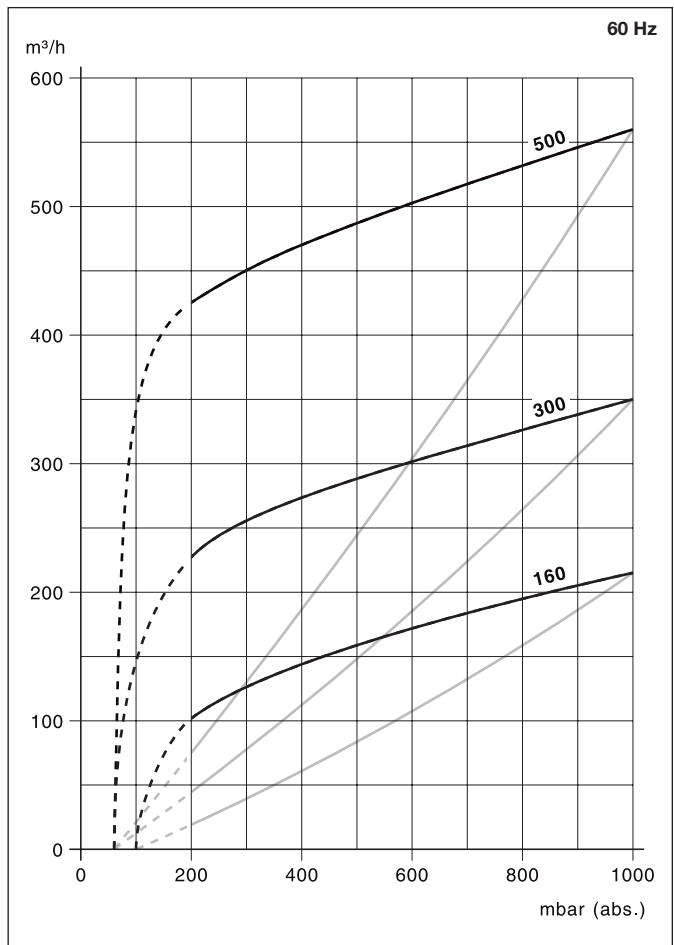
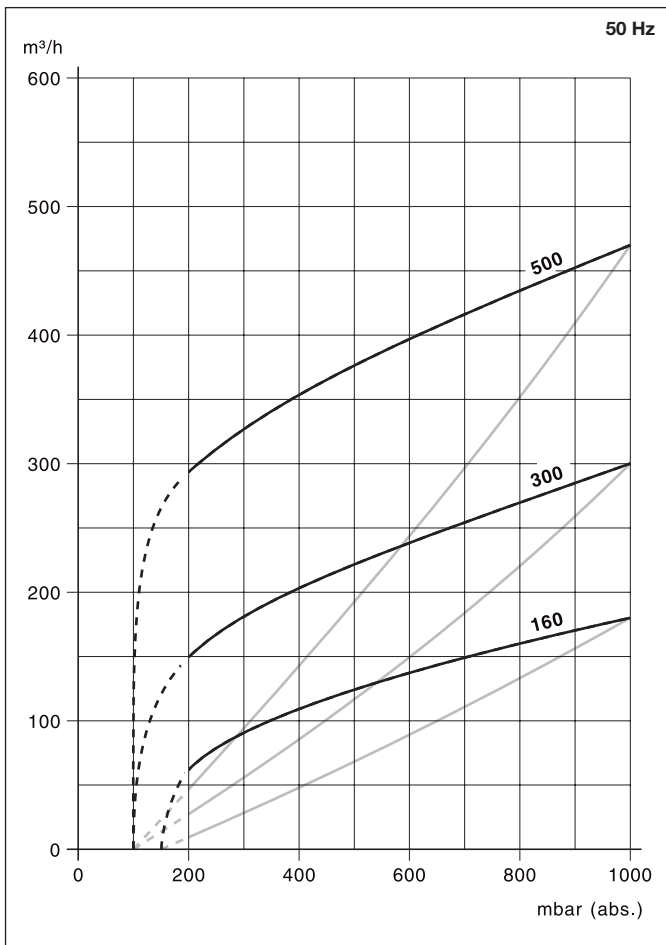

— bezogen auf den Zustand im Sauganschluß./ related to suction conditions at inlet connection./ relatif à l'état régnant à l'aspiration./ riferito alle condizioni in aspirazione.

- - - bezogen auf atmosphärischen Zustand./ related to atmospheric conditions./ relatif à l'état régnant de l'atmosphère./ riferito alle condizioni atmosferiche.

Die Kennlinien haben eine Toleranz von ± 10 %./ The curves have a tolerance of ± 10 %./ Les courbes ont une tolérance de ± 10 %./ Le curve hanno una tolleranza del ± 10 %.

Technische Änderungen vorbehalten!./ We reserve the right to alter technical information!./ Sous réserve de modification technique!./ Salvo modifiche tecniche!

Die Abmessungen a und ø w sowie die Stromaufnahme können je nach Motorfabrikat von den hier aufgeführten Angaben abweichen./ The dimensions a and ø w and/or the current drawn can differ when compared with the data list, depending on the motor type./ Les dimensions a et ø w ainsi que l'ampérage peuvent différer des données indiquées ci-dessus, selon le fabricant du moteur./ Le dimensioni a e ø w come la corrente nominale possono scostarsi leggermente dai dati qui riportati a seconda del costruttore del motore.

auf Anfrage

on request

sur demande

a richiesta